

VX DUO

M513-1

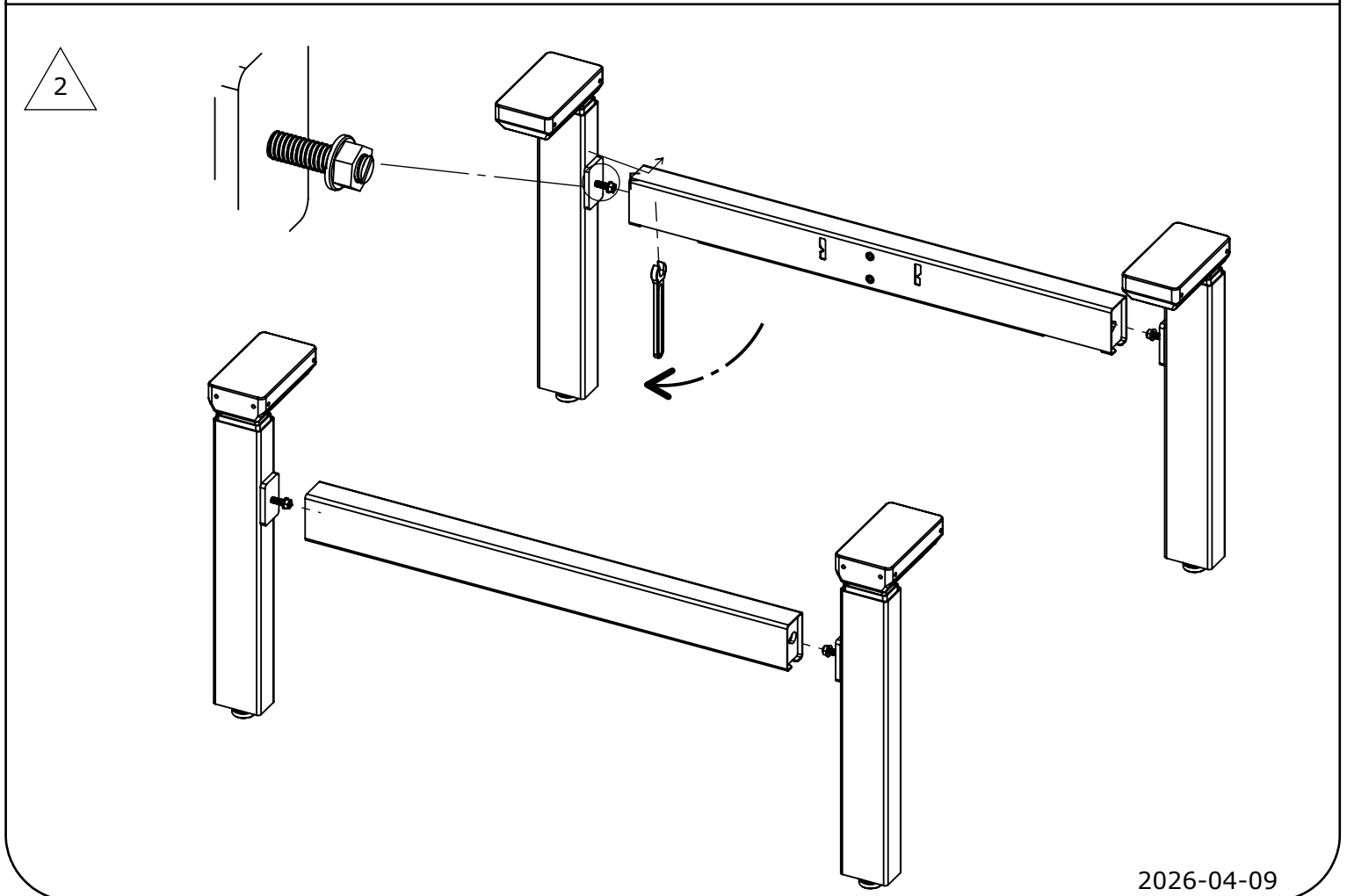

# ASSEMBLY INSTRUCTIONS

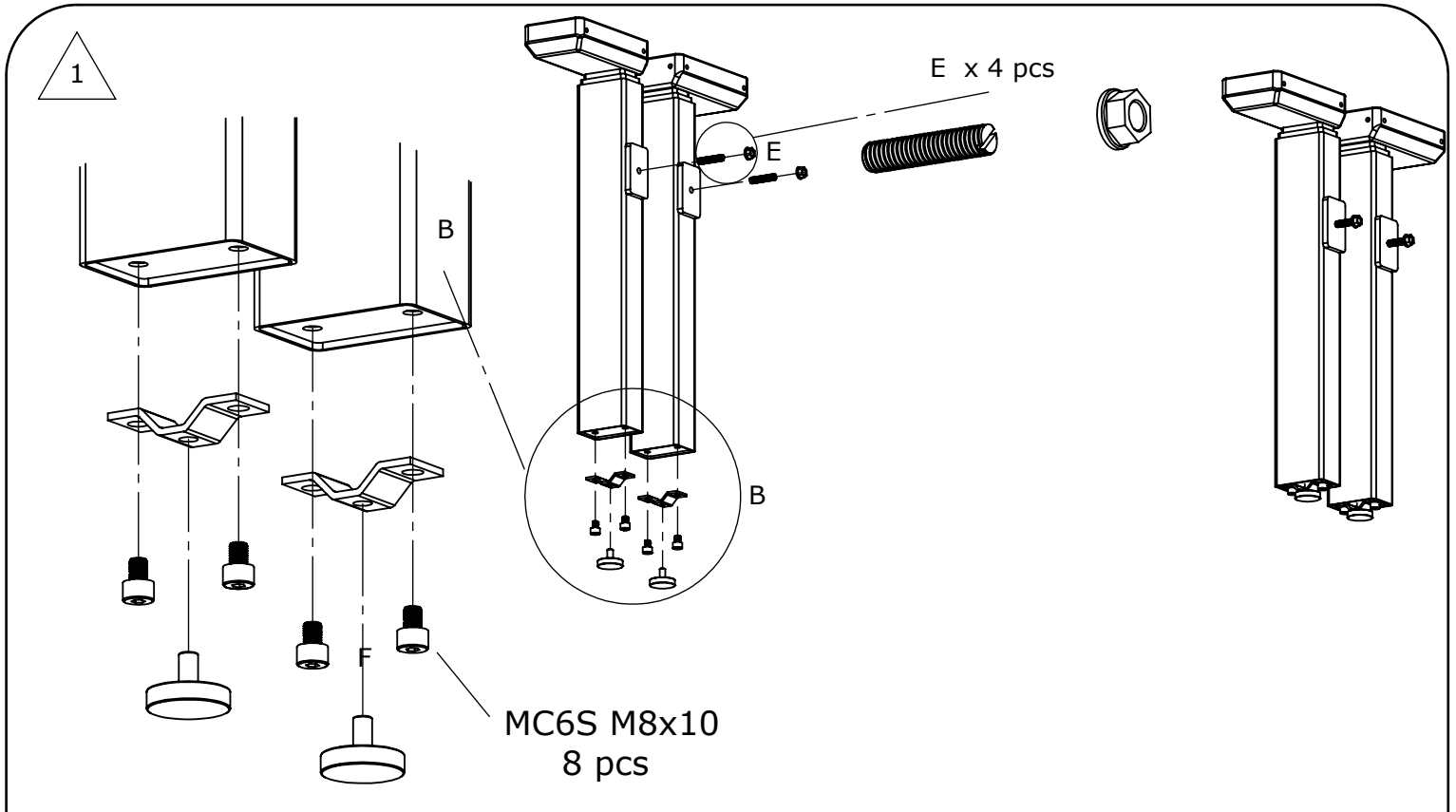

VX DUO

M513-1

3

COVER PLUG

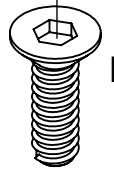

F6S M6x12  
16 pcs

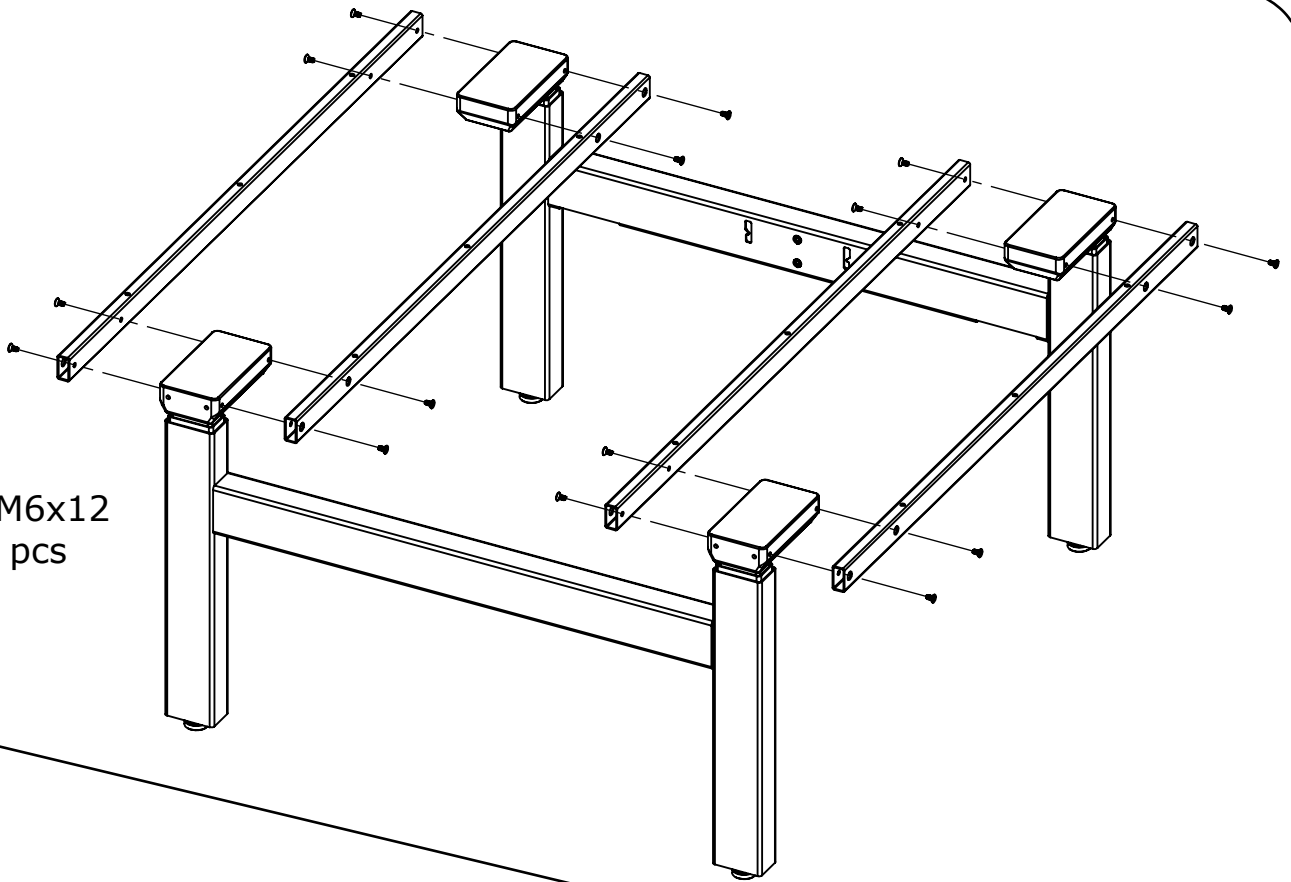

4

COVER PLUG

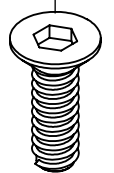

F6S M6x12  
8 pcs

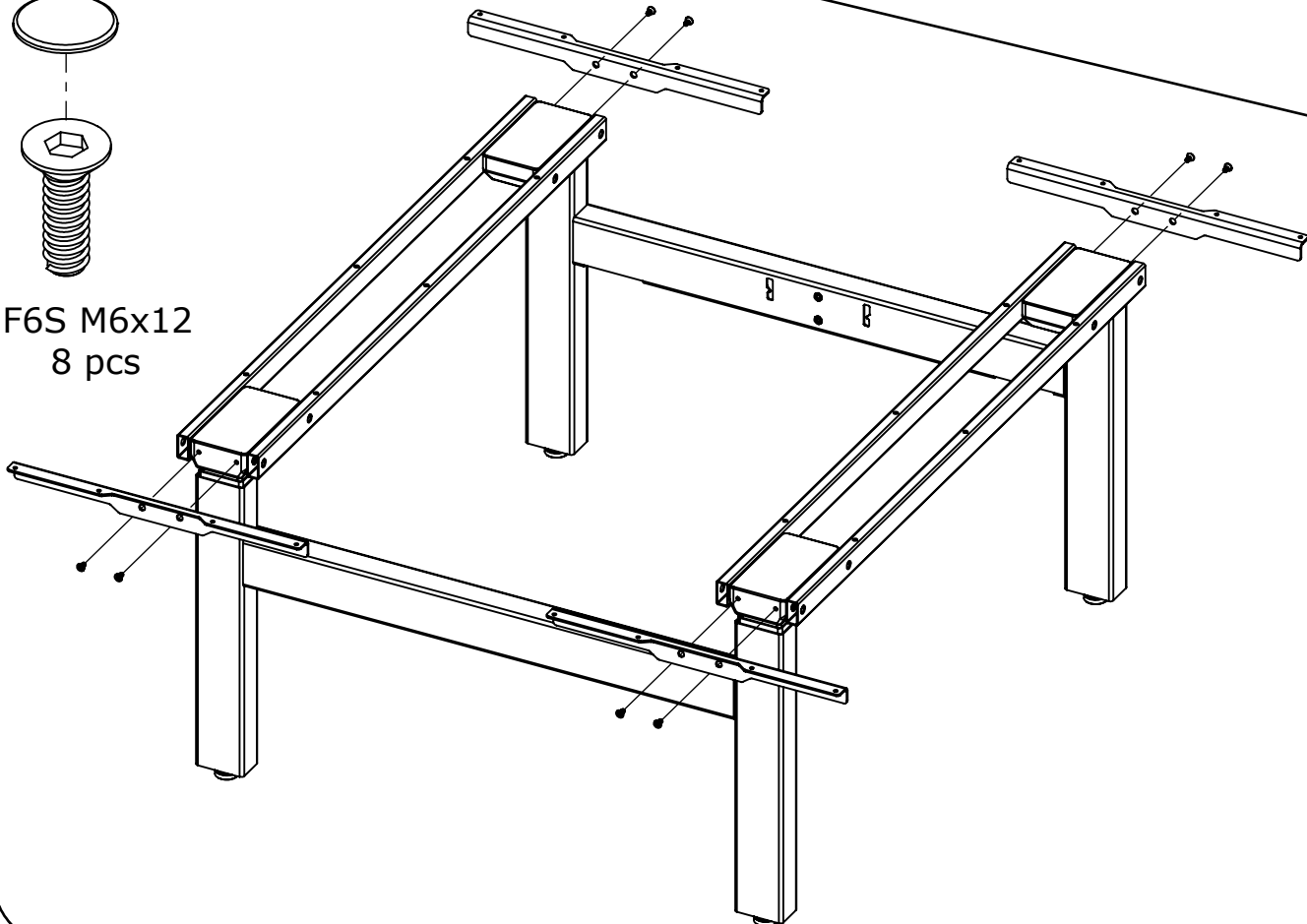

VX DUO

M513-1

5

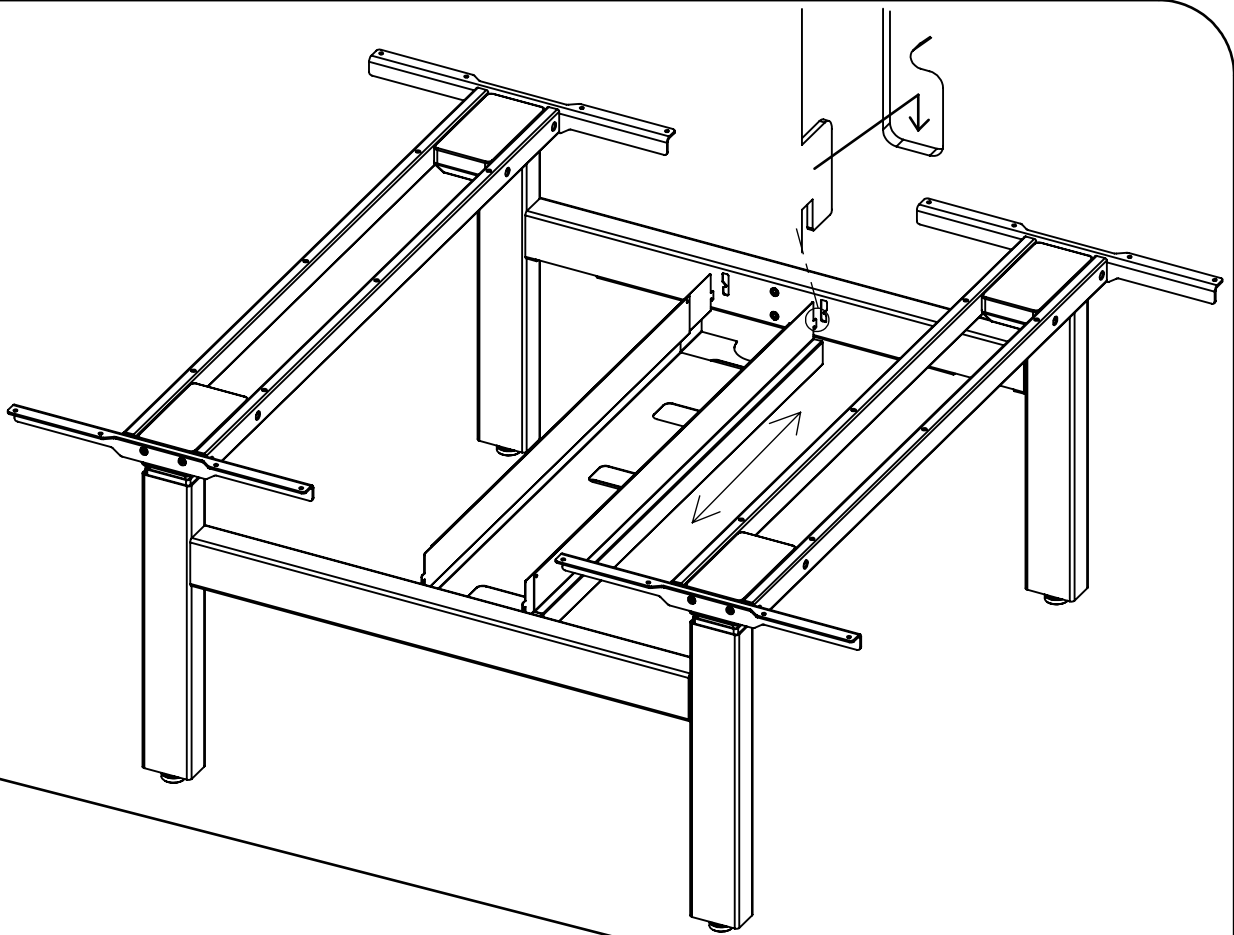

6

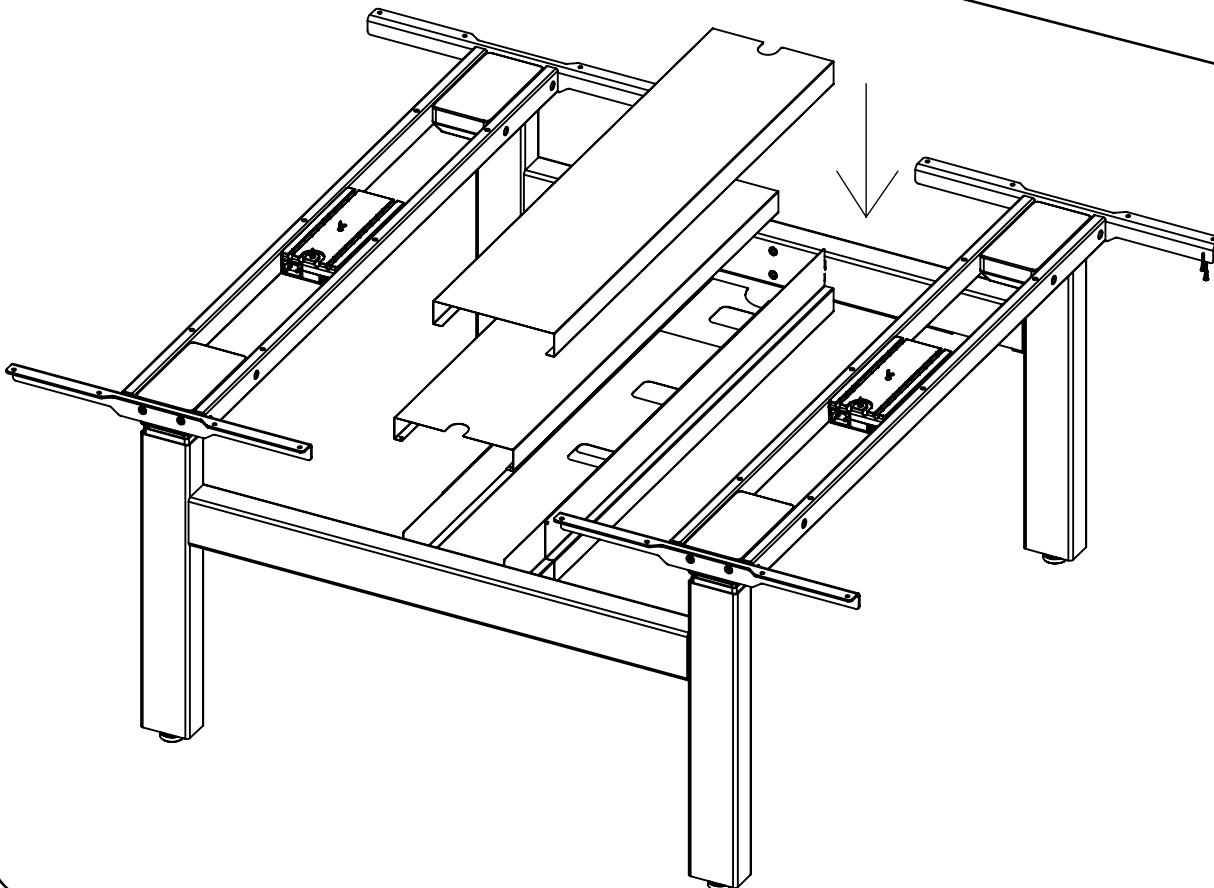

VX DUO

M513-1

7

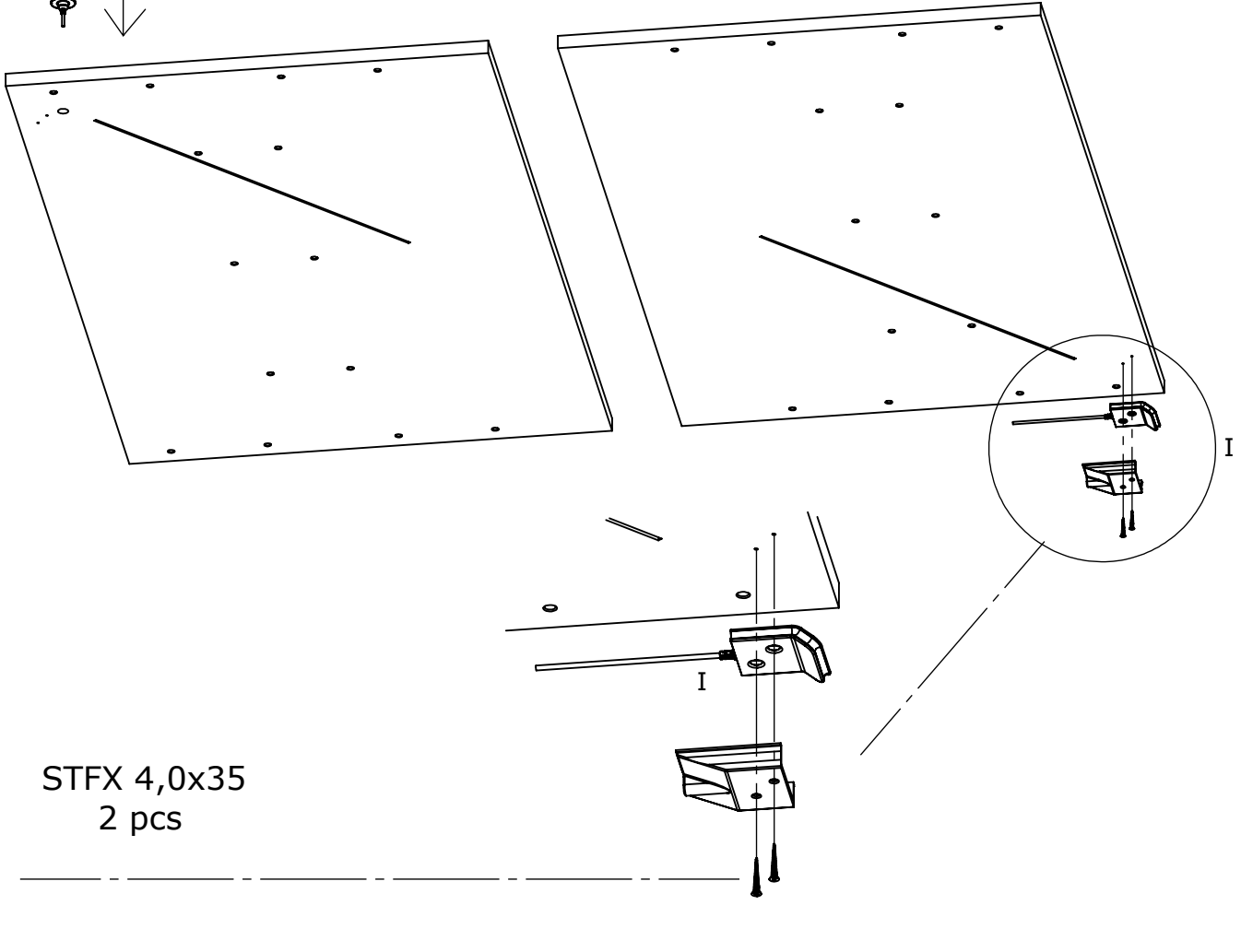
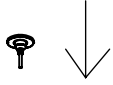

8

fix the cables from the hand controller before screwing the board in place

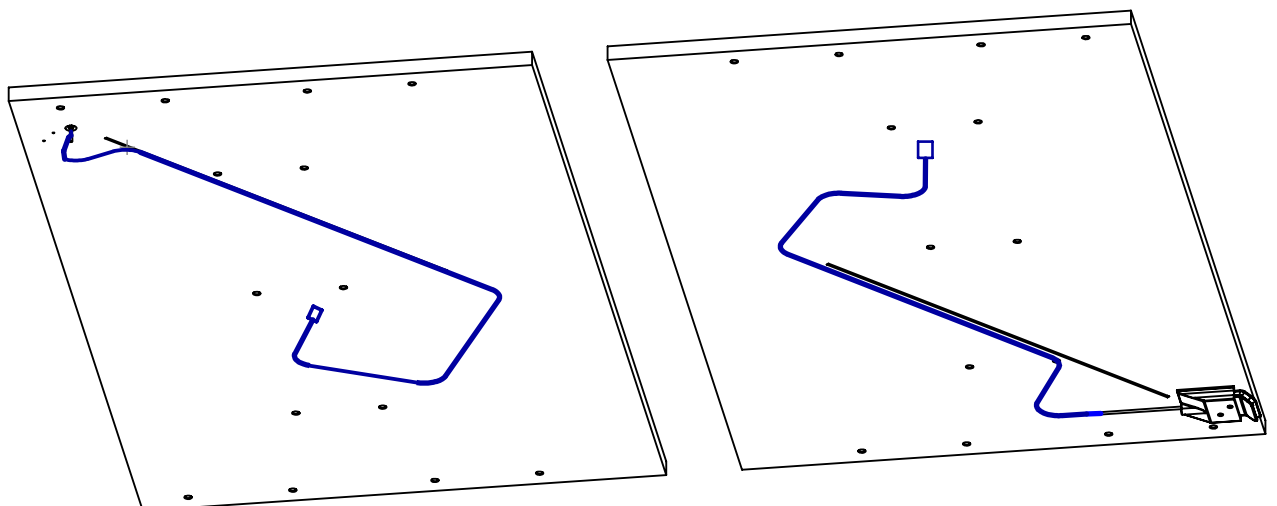

VX DUO

M513-1

9

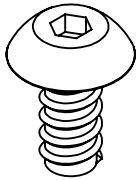
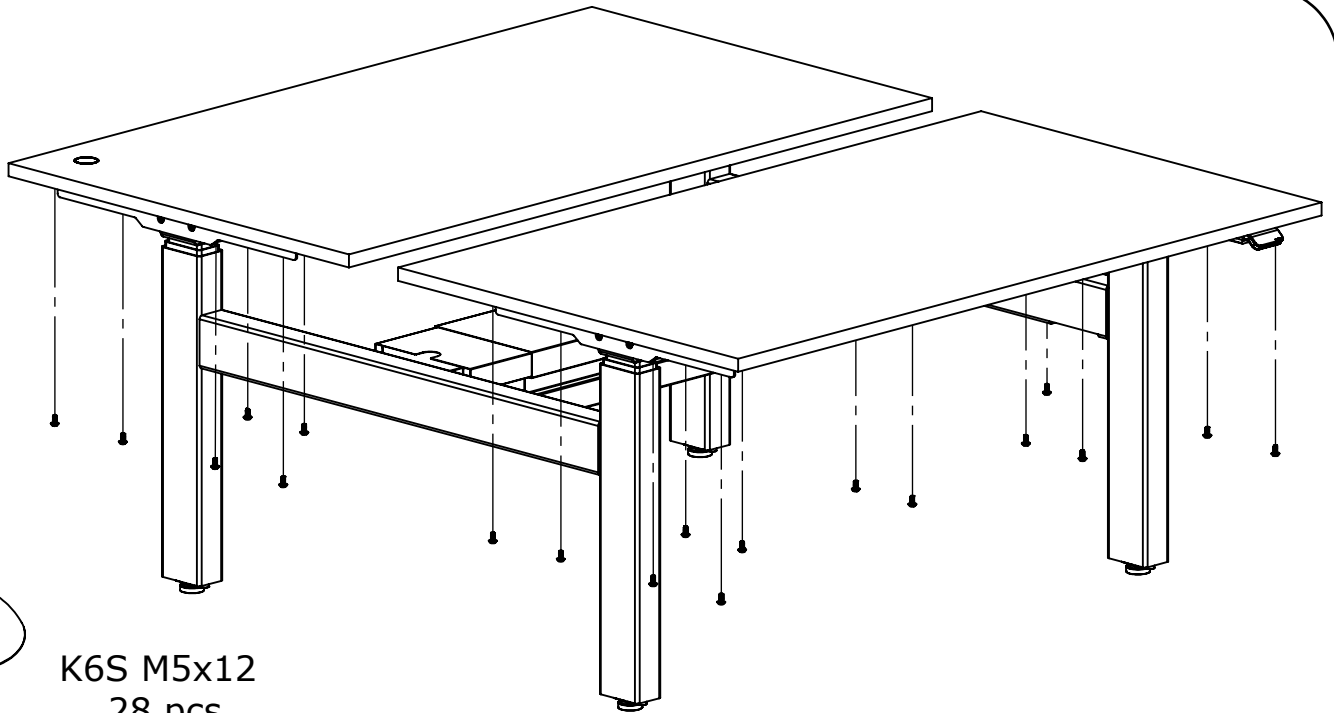

K6S M5x12  
28 pcs

10

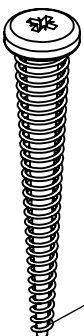
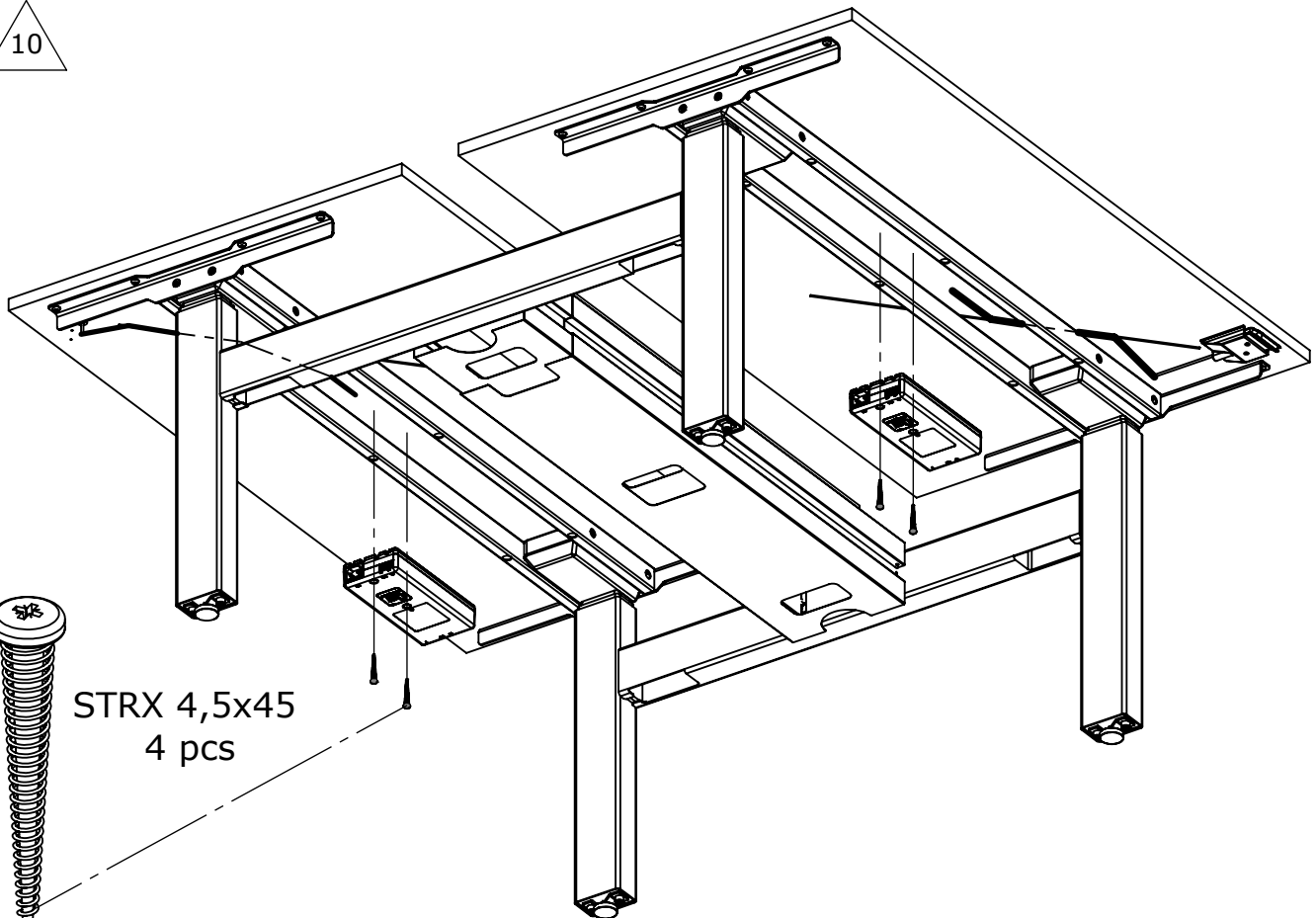

STRX 4,5x45  
4 pcs

install transformer - connecting all cables to the transformers

# ASSEMBLY INSTRUCTIONS

VX DUO

M513-1

connect several together with a connecting plate

